

DRG. No.

ALT.	DESCRIPTION	DATE

- HARD. & GROUND
- GROUND
- FINE FINISH MACHD.
- FINISH MACHD.
- ROUGH MACHD.
- FILED OR ROUGH GROUND

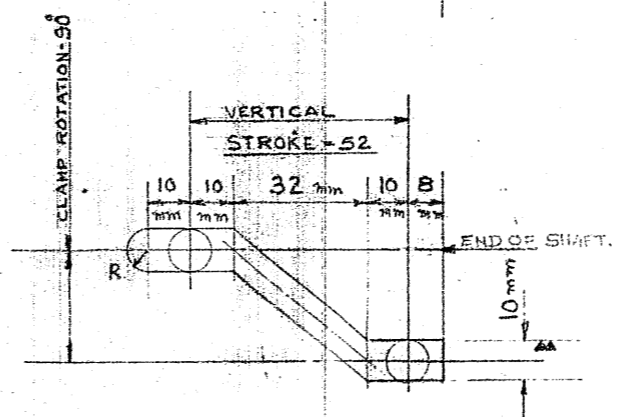
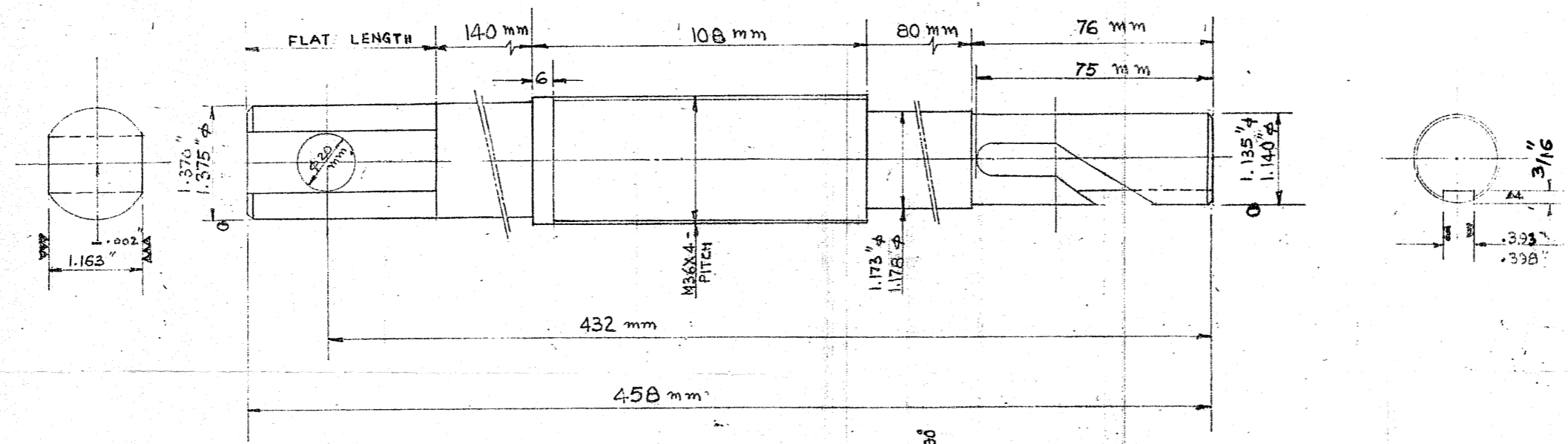

MAT'L - SPRING STEEL TO BS-EN 47
HARDNESS Rc 45-50

DEVELOPED GROOVE DETAILS

- NOTE:-**
- 1 ALL DIMENSIONS IN INCH UNLESS OTHERWISE SPECIFIED.
 - 2 BREAK ALL SHARP CORNERS 1/64"
 - 3 STAMP ON DRG. NO. FB(E)-36
COMP. NO.
C & D' NO.
 - 4 TOLERANCE ON DECIMAL DIMENSIONS NOT OTHERWISE SPECIFIED ±.002" FRACTIONAL ±.010" NOT CUMULATIVE.
 - 5 WELDMENT TO BE NORMALISED.

- WELD ALL AROUND
- FILLET
- SQUARE BUTT
- SINGLE V BUTT
- DOUBLE V BUTT
- SINGLE BEVEL BUTT
- STUD

REF. NO.	DESCRIPTION	MATL.	QTY. PER SET.	REMARKS
TITLE: SHAFT (CLAMPING FIX FOR CYL. BLOCK ON ANGULAR BORING)				
TYPE OF LOCO USED ON				
ALCO DRG. NO.				
SCALE		JIG AND TOOL OFFICE DIESEL LOCO WORKS VARANASI		
DATE	NO. OF SHEETS OF			
SHEET NO. OF	CHECKED	SUPDT. D.		
			A.P.E. (J.B.T.)	P.E. (T)
DRG. No.	FB(E)-36			

Y-3052