

ALT. NO.	ALTERATION	APPROVED BY SSE/ENG	INITIAL
Ⓐ	DRAWING REDRAWN.	SD/- 23.03.01	SD/- 23.03.01
Ⓑ	MISC.119 WAS IS:2062 Gr.B REF:FILE NO.dlw.m.65.117, Dt-23.11.2004	SD/- 18.07.06	SD/- 18.07.06
Ⓒ	1. 1-HOLE $\phi 1\frac{1}{4}$ ADDED. 2. DIM. $6\frac{5}{8}$ AND $7\frac{1}{2}$ ADDED. 3. $\frac{1}{4} \times 45^\circ$ CHAMFER AT BOTH SIDES OF PLATE ADDED. 4. SEMI MACHINING SKETCH ADDED. 5. NOTE NO. 3 ADDED.	SD/- 01.03.07	SD/- 01.03.07
Ⓓ	1. ONE HOLE $1\frac{1}{4}$ " DIA AND THEIR LOCATION DIMENSIONS DELETED. 2. SECTION K-K DELETED. REF.CHANGE NOTICE NO.CDE/ENG/ 16CYL./12CYL/2013/02 Dt02.02.13.		<i>Shankar</i> <i>14/2/13</i>

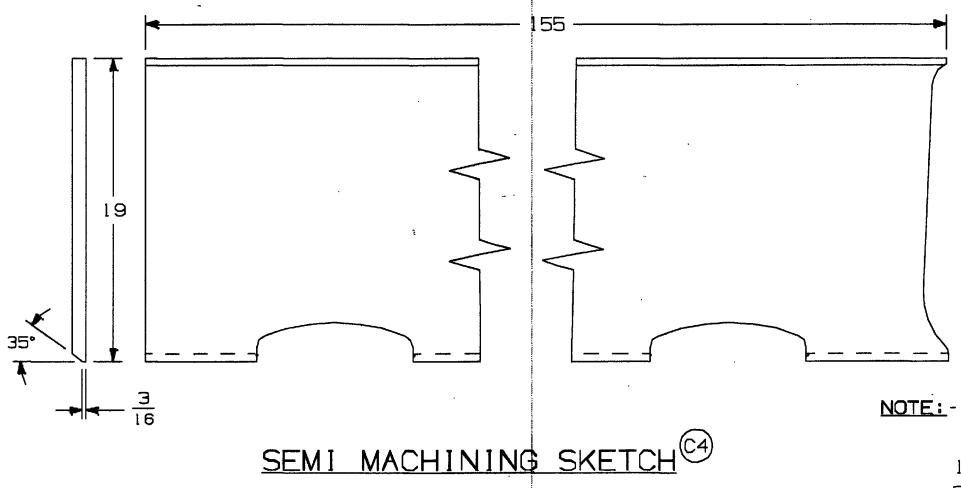
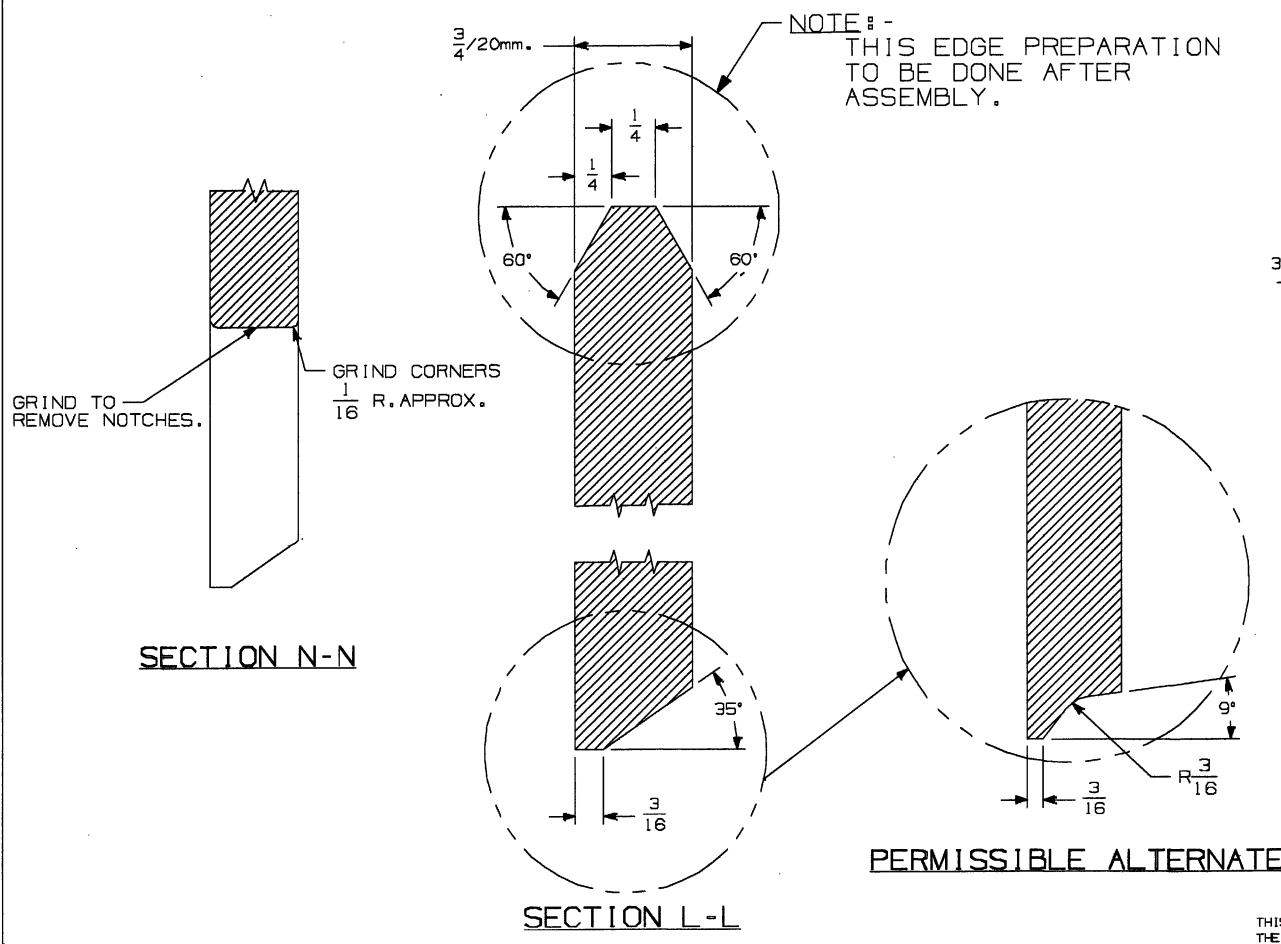
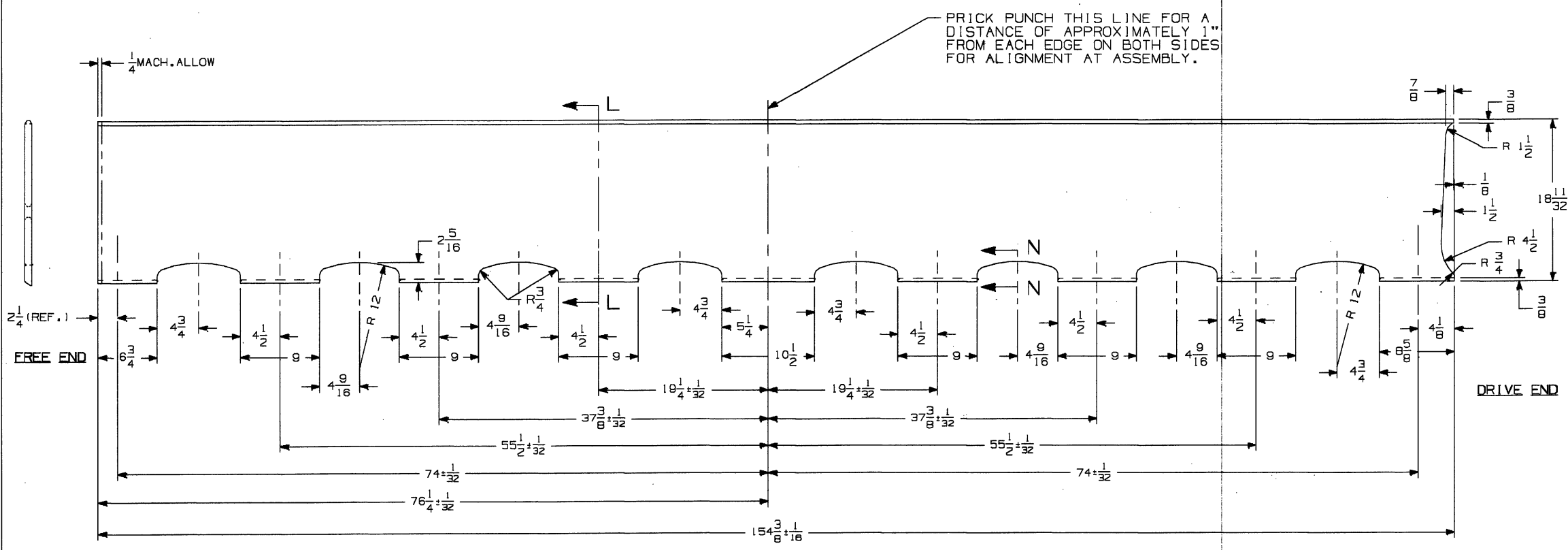

- NOTE :-
1. ALL CUT SURFACES UNLESS OTHERWISE NOTED.
 2. DIMENSION SHOWN DO NOT INCLUDE ALLOWANCES FOR CUTTING OR WELDING SHRINKAGE.
 3. VENDOR'S ARE REQUIRED TO SUPPLY THE CYL SIDE WALL (OUT SIDE) L.S. AS PER SEMI MACHINING SKETCH.

ALL DIMENSIONS ARE IN INCHES UNLESS OTHERWISE NOTED. IF TOLERANCES NOT STATED FRACTIONAL MACHINING DIMENSION ALLOW ± 0.010 DO NOT SCALE PRINT. ISSUING AUTHORITY : 500/RECORDS

THIS DRAWING IS A PROPERTY OF DLW/INDIAN RAILWAYS AND ANY UNAUTHORISED USE OF THE DRAWING WILL BE CONSIDERED ILLIGAL AND DLW/INDIAN RAILWAYS WILL HAVE RIGHT TO INITIATE LEGAL PROCEEDINGS AGAINST THE DEFAULTERS.

<i>Shankar</i>	<i>14.2.13</i>	10020019
Dj.CDE/ENG.	SPM/TOT.	ASSEMBLY PART NO.
APPROVED BY		

NO.OFF	DESCRIPTION & DIMENSION	ITEM	PART NO.	DRG.NO.	MATERIAL	SPECIFICATION
1	CYL SIDE WALL (OUT SIDE) (LEFT SIDE)				STL.PLATE	MISC-119
GROUP :				SUPERSEDED BY ALT 'c'		
				SUPERSEDES		
				SCALE	VERIFIED BY S.S.E/E <i>Shankar</i> 14.2.13	
				PROJECTION	C.H.D. <i>Shankar</i> 14.02.13	
				ALT. d	DRN. <i>Shankar</i>	
				PART NO. 10191094		
				DRG.NO: 31B71408		

DLW DIESEL LOCOMOTIVE WORKS
VARANASI