

HEAT TREATMENT NUMBER	MATERIAL AND SPECIFICATION	ALT. NO.	ALTERATIONS	SUPERCHD BY SSE/DRG	VALIDATED BY AWM/LD	DATE
	SEE FORGING DRG.	परि. सं.	परिवर्तन	सु.अ.अ.क.ता. सं.अ.अ./सं.	प्रमाणित सं.अ.अ./सं.अ.अ.	दिनांक
		(Z)	NOTE-1 ADDED.	(Signature)	ke	10 ³ / _{2K}
		(Y)	NOTE-1 FOR PACKING DELETED VIDE CME'S APPROVAL DT. 20.11.2K.	(Signature)	(Signature)	25 ¹¹ / _{2K}
		(X)	VIEW CORRECTED. (VIDE DLW ALT Q.)	(Signature)	DYCME (Signature)	20 ⁷ / ₂₀₀

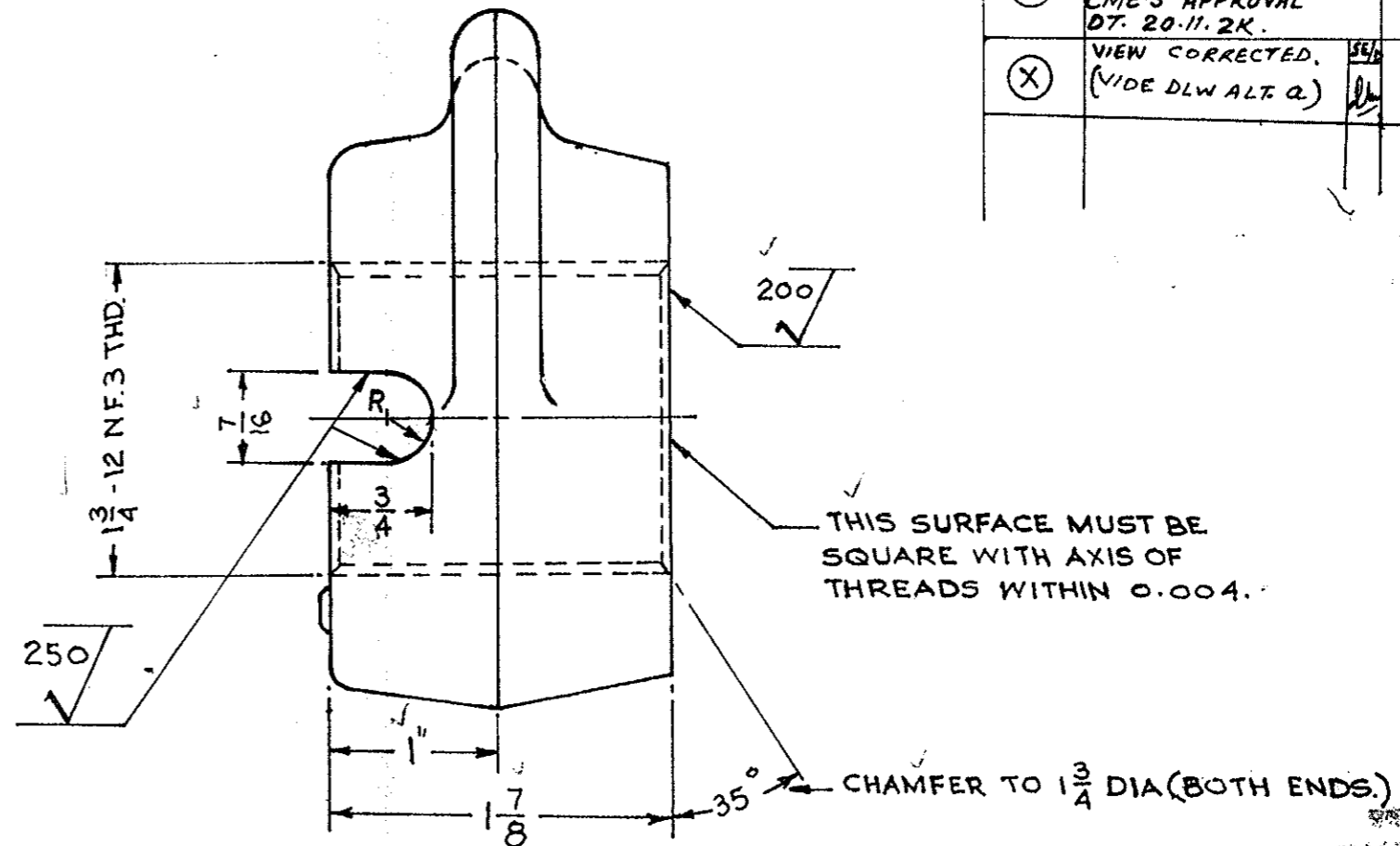
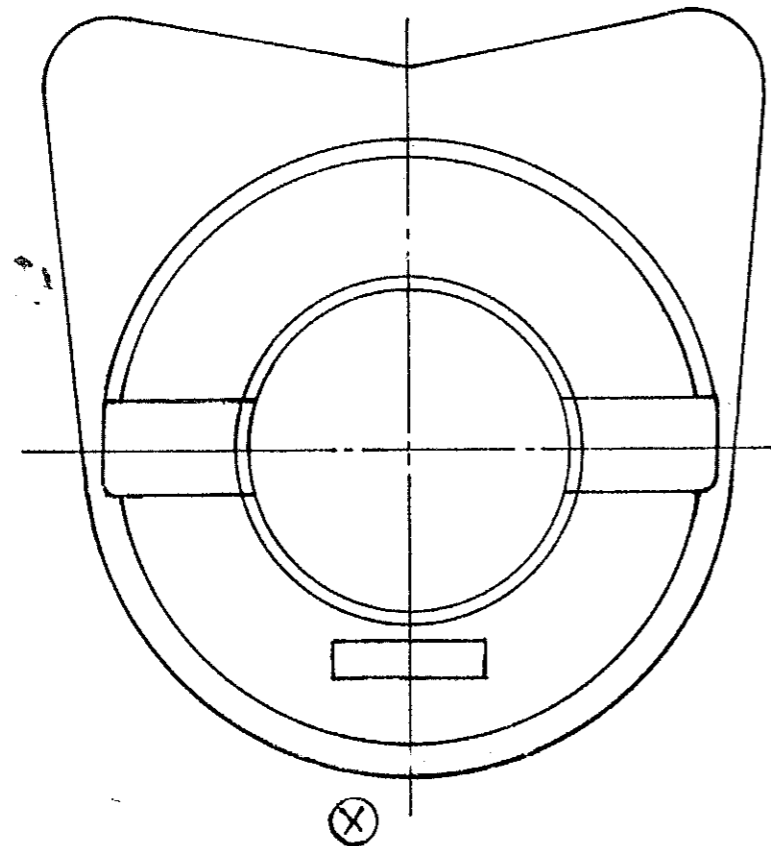

BREAK SHARP EDGES APPROX. 1/16 R.
REMOVE ALL BURRS.

VALIDATED

SIGN
 DESG WM/PLD
 DATE 18/11/97

FOR FORGING DRG. SEE PART NO. 10140219.

ALL DIMENSIONS ARE IN INCHES
 UNLESS OTHERWISE NOTED.
 IF TOLERANCES NOT STATED FRACTIONAL
 MACHINING DIMENSIONS ALLOW ± 0.010.
 DO NOT SCALE THE PRINT.

THIRD ANGLE PROJECTION

12	-	10020329	SUPERSEDES SCALE 1:1	AWM	DY. CME
-	12	10021115			
-	16	10020160			
6 CYL. INLINE ENGINE			NUT-WINGED MACHINING (MAIN BRG. STUD INT.)	SDO	
12 CYL. VEE ENGINE				CHD	
16 CYL. VEE ENGINE				DRN.	29.9.81
				TRD	
DIESEL COMPONENT WORKS PATIALA			SHEET No.	NO. OF SHEETS	
			PART NO. 10140207		

(AA) 15C 72068-2 10052/1 270

15C 72068-2 10052/1